

**TESLA Report 2006-04**  
**DESY Thesis 2006-021**



**WARSAW UNIVERSITY OF TECHNOLOGY**  
Faculty of Electronics and Informational Technologies  
Institute of Electronic Systems  
ELHEP Laboratory  
DESY TESLA LLRF Team

**Jerzy Stefan Zieliński**

**Synchronic, optical transmission data link  
integrated with FPGA circuits**  
(for TESLA LLRF control system)

Mentor:  
Prof. D.Sc. Ryszard Romaniuk, WUT

Tutor:  
Ph.D. Krzysztof Poźniak, WUT

In cooperation with  
Dr Stefan Simrock, DESY, Hamburg

Warsaw, May 2006

## Contents

<b>ABSTRACT</b> .....	<b>4</b>
<b>INTRODUCTION</b> .....	<b>5</b>
<i>The X-FEL Laser Project</i> .....	5
<i>The LLRF system &amp; Stratix GX devices in LLRF Project</i> .....	6
<b>INTRODUCTION TO THE STRATIX GX DEVICE</b> .....	<b>8</b>
<i>Overview</i> .....	8
<i>Basic Features</i> .....	9
<i>Stratix GX Transceivers</i> .....	12
<i>Transceiver Blocks</i> .....	12
<b>TRANSMITTER PATH</b> .....	<b>15</b>
<i>Transmitter PLL</i> .....	15
<i>Transmitter Phase Compensation FIFO Buffer</i> .....	16
<i>Byte Serializer</i> .....	16
<i>8B/10B Encoder</i> .....	16
<i>Serializer (Parallel-to-Serial Converter)</i> .....	17
<i>Transmit Buffer</i> .....	18
<i>Programmable Output Driver</i> .....	18
<i>Programmable Transmitter Termination</i> .....	19
<b>RECEIVER PATH</b> .....	<b>19</b>
<i>Receiver Input Buffer</i> .....	19
<i>Receiver PLL &amp; CRU</i> .....	20
<i>Deserializer (Serial-to-Parallel Converter)</i> .....	20
<i>Word Aligner</i> .....	20
<i>8B/10B Decoder</i> .....	22
<i>Applications &amp; Protocols</i> .....	23
<b>THE LONG-DATA-VECTORS TRANSCEIVER MODULE IN THE STRATIX GX DEVICE</b> .....	<b>24</b>
<i>Introduction</i> .....	24
<i>The Long-Data-Vector serializer</i> .....	26
<i>The hardware transceiver module in the Stratix GX FPGA structure</i> .....	30
<i>The long data vector deserializer</i> .....	32
<b>TESTS OF THE LONG-DATA-VECTOR TRANSCEIVER MODULE</b> .....	<b>35</b>
SIMULATIONS IN THE QUARTUS II SOFTWARE.....	35
HARDWARE RANDOM TESTS.....	36

**SUMMARY ..... 38**  
**LITERATURE ..... 41**

**ACKNOWLEDGMENT**

We acknowledge the support of the European Community Research Infrastructure Activity under the FP6 “Structuring the European Research Area” program (CARE, contract number RII3-CT-2003-506395).

## Abstract

The X-ray free-electron laser X-FEL that is being planned at the DESY research center in cooperation with European partners will produce high-intensity ultra-short X-ray flashes with the properties of laser light. This new light source, which can only be described in terms of superlatives, will open up a whole range of new possibilities for the natural sciences. It could also offer very promising opportunities for industrial users.

SIMCON (SIMulator and CONtroller) is the project of the fast, low latency digital controller dedicated to the LLRF<sup>1</sup> system in VUV FEL experiment. It is being developed by the ELHEP<sup>2</sup> group in the Institute of Electronic Systems at Warsaw University of Technology. The main purpose of the project is to create a controller to stabilize the vector sum of fields in cavities of one cryo-module in the experiment. The device can be also used as the simulator of the cavity and test bench for other devices.

The synchronic, optical link project was made for the accelerator X-FEL laser TESLA, the LLRF control system experiment at DESY, Hamburg. The control and diagnostic data is transmitted up to 2.5Gbit/s through a plastic fiber in a distance up to a few hundred meters. The link is synchronized once after power up, and never resynchronized when data is transmitted with maximum speed. The one way link bit error rate is less than  $10^{-15}$ . The transceiver component written in VHDL that works in the dedicated Altera® Stratix® GX FPGA circuit. During the work in the PERG laboratory a 2,5Gbit/s serial link with the long vector parallel interface transceiver was created. Long-Data-Vector transceiver transmits 16bit vector each 8ns with 120ns latency.

---

<sup>1</sup> Low level Radio Frequency

<sup>2</sup> Electronics for High Energy Physics

Introduction

The X-FEL Laser Project

The X-ray free-electron laser XFEL will produce high-intensity ultra-short X-ray flashes with the properties of laser light. The experiment that is being planned at the DESY research center in cooperation with European partners introduces a new light source, that can only be described in terms of superlatives. The X-FEL laser will open up a whole range of new possibilities for the natural sciences. The overall layout of the X FEL linear accelerator and laser facility is shown in Figure 1.

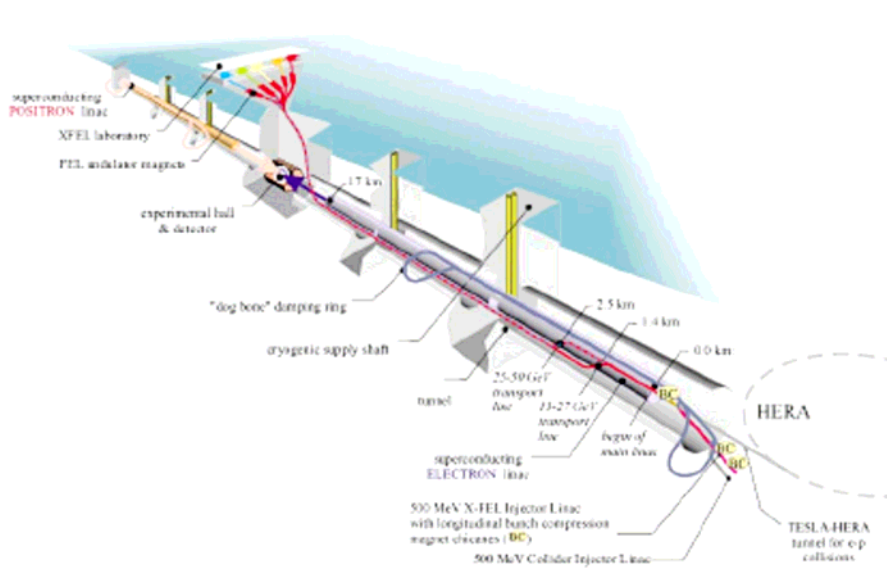

Figure 1 X-FEL facility layout

The main X FEL parameters are:

- Total length of the facility: approx. 3.4 km
- Accelerator tunnel: approx. 2.1 km
- Depth underground: 6 - 38 m
- Wavelength of X-ray radiation: 6 to 0.085 nanometers (nm) corresponding to electron energies of 10 to 20 billion electron volts (GeV)
- Length of radiation pulses: below 100 femtoseconds (fs)

The planned facility will include a superconducting linear accelerator, and a full control system with measurement capabilities. The accelerator brings tightly bundled "bunches" of electrons to energies of several billion electron volts. As electrons go through the accelerator cavities, they emit X-ray radiation that amplifies itself during the flight. In result extremely short and intense X-ray flashes with laser properties appears. The X-ray laser requires extremely high quality of an electron beam. The TESLA superconducting accelerator technology makes it possible to generate precise beam of electrons.

The cavities of the accelerator are grouped in cryomodules.(Figure 2) Each cryomodule consists of 32 cavities. In general, four cryomodules are driven by one klystron. In order to accelerate the beam, the electromagnetic field inside the cavity must be stabilized. The regulation of the field is performed by the LLRF system The system controls I and Q components of the cavity field (which corresponds to real and imaginary part of the field vector).

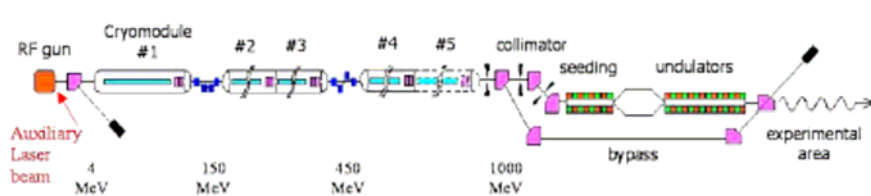

Figure 2 The layout of accelerator module construction

### **The LLRF system & Stratix GX devices in LLRF Project**

The LLRF control system is responsible for a precise repetitive loading of the cavity with the EM high power energy field and for the EM field stabilization. A single channel system works with a

single cavity. The 8 channel system works with a single TESLA module (ACC) of 8 cavities. The modular electronic work up to 32 cavities per an LLRF system. In the future the system will be able to control a much larger number of system components referring to the X-FEL system project.

In the above context, The LLRF system may be represented as the multichannel, source-synchronous hardware concentrator. The signals from various number of A/D converters are delivered to the concentration module via elemental signal boards and elements.

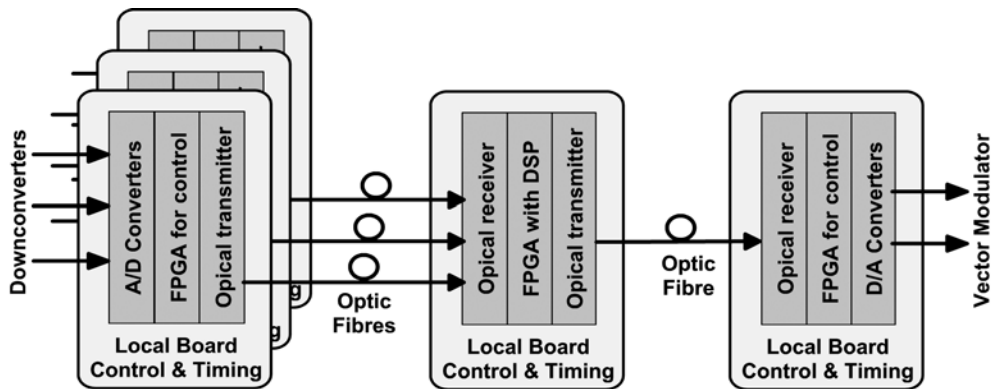

Figure 3 LLRF system components connections diagram

The LLRF is a distributed, multichannel control and data transmission system. The control and data acquisition boards are connected together with fast data links. (Figure 3) Standard wires or fiber cables can be used for data transmission there. Standard Cu wires may be influenced by the strong EM field and data, which travels through the wire can be scrambled. Optic fiber is EM field resistant and data can not be scattered in an easy way. Fiber is a perfect choice for boards connection. The fast optical link can be established at 2,5 Gbps using Stratix GX Devices.

## **Introduction to the Stratix GX Device**

Expansion in the telecommunications market and growth in Internet use requires systems to move more data faster than ever. To meet this demand, system designers rely on solutions such as differential signaling and emerging high-speed interface standards including RapidIO, POS-PHY 4, SFI-4, or XSBI. These new protocols support differential data rates up to 1 gigabit per second (Gbps) and higher. At these high data rates, it becomes more challenging to manage the skew between the clock and data signals. One solution to this challenge is to use clock data recovery (CDR) to eliminate skew between data channels and clock signals. Another potential solution, dynamic phase alignment (DPA), is beginning to be incorporated by some of these protocols. The Stratix™ GX family of devices are the first FPGA devices to have an embedded dynamic phase aligner.

### **Overview**

The Stratix® GX family combines high-speed serial transceivers with a scalable, high-performance logic array. Stratix GX devices include 4 to 20 high-speed transceiver channels, each incorporating a clock data recovery (CDR) technology and embedded serializer-deserializer (SERDES) capability at data flow rates of up to 3.1875Gbit/s. Transceivers are grouped by four-channel transceiver blocks. The Stratix GX FPGA technology offers scalable, high-performance architecture, which makes Stratix GX devices ideal for high-speed backplane interface, chip-to-chip, and communications protocol-bridging applications.



## Basic Features

Transceiver block features are as follows:

- High-speed serial transceiver channels with CDR<sup>3</sup> provides 500-megabits per second (Mbps) to 3.1875-Gbps full-duplex operation
- Devices are available with 4, 8, 16, or 20 high-speed serial transceiver channels providing up to 127.5 Gbps of full-duplex serial bandwidth
- Support for transceiver-based protocols, including 10 Gigabit Ethernet attachment unit interface (XAUI), Gigabit Ethernet (GigE), and SONET/SDH
- Compatible with PCI Express, SMPTE 292M, Fibre Channel, and Serial RapidIO I/O standards
- Programmable differential output voltage (VOD), pre-emphasis, and equalization settings for improved signal integrity
- Individual transmitter and receiver channel power-down capability implemented automatically by the Quartus® II software for reduced power consumption during non-operation
- Programmable transceiver-to-FPGA interface with support for 8-, 10-, 16-, and 20-bit wide data paths
- 1.5-V pseudo current mode logic (PCML) for 500 Mbps to 3.1875 Gbps
- Support for LVDS, LVPECL, and 3.3-V PCML on reference clocks and receiver input pins (AC-coupled)
- Built-in self test (BIST)
- Hot insertion/removal protection circuitry Stratix GX Transceivers
- Pattern detector and word aligner supports programmable patterns

---

<sup>3</sup> Clock Data Recovery

- 8B/10B encoder/decoder performs 8- to 10-bit encoding and 10-to 8-bit decoding
- Rate matcher compliant with IEEE 802.3-2002 for GigE mode and with IEEE 802-3ae for XAUI mode
- Channel bonding compliant with IEEE 802.3ae (for XAUI mode only)
- Device can bypass some transceiver block features if necessary

FPGA features are as follows:

- 10,570 to 41,250 logic elements (LEs)
- Up to 3,423,744 RAM bits (427,968 bytes) available without reducing logic resources
- TriMatrix™ memory consisting of three RAM block sizes to implement true dual-port memory and first-in-out (FIFO) buffers
- Up to 16 global clock networks with up to 22 regional clock networks per device region
- High-speed DSP blocks provide dedicated implementation of multipliers (faster than 300 MHz), multiply-accumulate functions, and finite impulse response (FIR) filters
- Up to eight general usage phase-locked loops (four enhanced PLLs and four fast PLLs) per device provide spread spectrum, programmable bandwidth, clock switchover, real-time PLL reconfiguration, and advanced multiplication and phase shifting
- Support for numerous single-ended and differential I/O standards
- High-speed source-synchronous differential I/O support on up to 45 channels for 1-Gbps performance
- Support for source-synchronous bus standards, including 10-Gigabit Ethernet XSBI, Parallel RapidIO, UTOPIA IV, Network Packet Streaming Interface (NPSI), HyperTransport™ technology, SPI-4 Phase 2 (POS-PHY Level 4), and SFI-4
- Support for high-speed external memory, including zero bus turnaround (ZBT) SRAM, quad data rate (QDR and QDRII) SRAM, double data rate (DDR) SDRAM, DDR fast cycle RAM (FCRAM), and single data rate (SDR) SDRAM

- Support for multiple intellectual property megafunctions from Altera® MegaCore® functions and Altera Megafunction Partners Program (AMPPSM) megafunctions Support for remote configuration updates
- Dynamic phase alignment on LVDS receiver channels

The features of different models of the Stratix GX devices are presented in the Table 1:

Feature	EP1SGX10C EP1SGX10D	EP1SGX25C EP1SGX25D EP1SGX25F	EP1SGX40D EP1SGX40G
LEs	10,570	25,660	41,250
Transceiver channels	4, 8	4, 8, 16	8, 20
Source-synchronous channels	22	39	45
M512 RAM blocks (32 × 18 bits)	94	224	384
M4K RAM blocks (128 × 36 bits)	60	138	183
M-RAM blocks (4K × 144 bits)	1	2	4
Total RAM bits	920,448	1,944,576	3,423,744
Digital signal processing (DSP) blocks	6	10	14
Embedded multipliers	48	80	112
PLLs	4	4	8

Table 1 Features of the Stratix GX devices

The Stratix GX device family supports high-speed serial transceiver blocks. Channels are clustered in a four-channel serial transceiver building blocks and deliver high-speed bidirectional point-to-point data transmissions to provide fast, full-duplex data transmission.

The Stratix GX devices supports such source-synchronous, transmission protocols as: LVDS, LVPECL, 3.3-V PCML, or HyperTransport technology I/O standards.

## **Stratix GX Transceivers**

Stratix® GX devices incorporate dedicated embedded circuitry on the right side of the device, which contains up to 20 high-speed 3.1875Gbit/s serial transceiver channels. Each Stratix GX transceiver block contains four full-duplex channels and supporting logic to transmit and receive high-speed serial data streams. The transceiver block uses the channels to deliver bidirectional point-to-point data transmissions with up to 3.1875Gbit/s of data transition per channel.

### **Transceiver Blocks**

Stratix GX devices are organized into four-channel blocks with four full-duplex channels per block. (Figure 4) Each self-contained Stratix GX gigabit transceiver block supports a variety of embedded functions:

- Supports frequencies up to 3.1875Gbit/s
- Integrates serializer/deserializer (SERDES), clock data recovery (CDR), word aligner, channel aligner, rate matcher, 8B/10B encoder/decoder, byte serializer/deserializer, and phase compensation first-in first-out (FIFO) modules
- Supports flexible reference clock generation capabilities, including a dedicated transmitter phase-locked loop (PLL) and four receiver PLLs per gigabit transceiver block
- Includes built-in self test (BIST) capability, including embedded Pseudo Random Binary Sequence (PRBS) pattern generation and verification

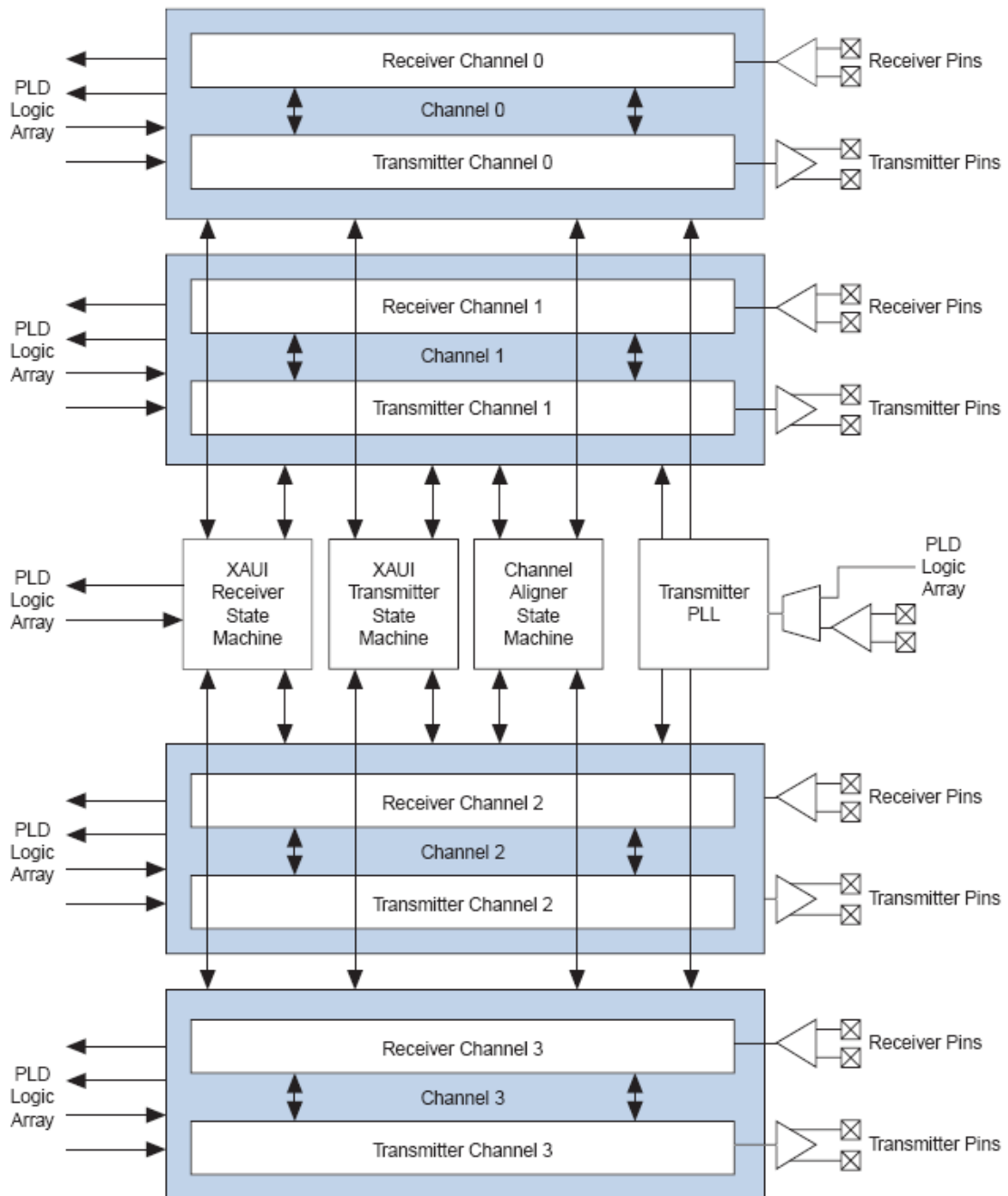

Figure 4 Stratix GX Transceiver Block Diagram

Each Stratix GX transceiver channel consists of a transmitter and receiver.

The transmitter contains:

- Transmitter PLL
- Transmitter phase compensation FIFO buffer
- Byte serializer
- 8B/10B encoder
- Serializer (parallel to serial converter)
- Transmitter output buffer

The receiver contains:

- Input buffer
- Clock recovery unit (CRU)
- Deserializer
- Pattern detector and word aligner
- Rate matcher and channel aligner
- 8B/10B decoder
- Receiver logic array interface

The Stratix GX transceiver functions are set through the Quartus II software, where programmable pre-emphasis, programmable equalizer, programmable VOD, and the other transceiver components can be dynamically set. Each Stratix GX transceiver channel is capable of BIST<sup>4</sup> generation and verification in addition to various loopback modes.

---

<sup>4</sup> Build In Self Test

Stratix GX transceivers provide physical coding sublayer (PCS) and physical media attachment (PMA) implementation for protocols such as: 10-gigabit XAUI and GigE. The PCS portion of the transceiver consists of the logic array interface, 8B/10B encoder/decoder, pattern detector, word aligner, rate matcher, channel aligner, and the BIST and pseudo-random binary sequence pattern generator/verifier. The PMA portion of the transceiver consists of the serializer/deserializer, the CRU, and the I/O buffers.

## Transmitter Path

This section describes the data path through the Stratix GX transmitter.

Path of Data in Stratix GX transmitter is as follows:

- Transmitter PLL<sup>5</sup>
- Transmitter phase compensation FIFO<sup>6</sup> buffer
- Byte serializer
- 8B/10B encoder
- Serializer (parallel to serial converter)
- Transmitter output buffer

## Transmitter PLL

The *inclk* clock is the input into the transmitter PLL. There is one *inclk* clock per transceiver block. This clock can be fed by either the *refclk* pin, PLD routing, or the inter-transceiver routing line. The transmitter PLL in each transceiver block clocks the circuits in the transmit path. The transmitter PLL is also used to train the receiver PLL. If no transmit channels are used

---

<sup>5</sup> Phase Locked Loop

<sup>6</sup> First In First Out

in the transceiver block, the transmitter PLL can be turned off. The transmitter PLL has a programmable loop bandwidth that can be set to low or high. The loop bandwidth parameter can be statically set in the Quartus II software.

### **Transmitter Phase Compensation FIFO Buffer**

The transmitter phase compensation FIFO buffer resides in the transceiver block at the PLD boundary. This FIFO buffer compensates for the phase differences between the transmitter reference clock (*inclk*) and the PLD interface clock (*tx\_coreclk*). The phase difference between the two clocks must be less than 360°. The PLD interface clock must also be frequency locked to the transmitter reference clock. The phase compensation FIFO buffer is four words deep and cannot be bypassed.

### **Byte Serializer**

The byte serializer takes double-width words (16 or 20 bits) from the PLD interface and converts them to a single width word (8 or 10 bits) for use in the transceiver. The transmit data path after the byte serializer is single width (8 or 10 bits). The byte serializer is bypassed when single width mode (8 or 10 bits) is used at the PLD interface.

### **8B/10B Encoder**

The 8B/10B encoder translates 8-bit wide data, described as the data string or the control string by control enable bit into a 10-bit encoded data. The 8B/10B encoder can be bypassed. Figure diagrams the encoding process.



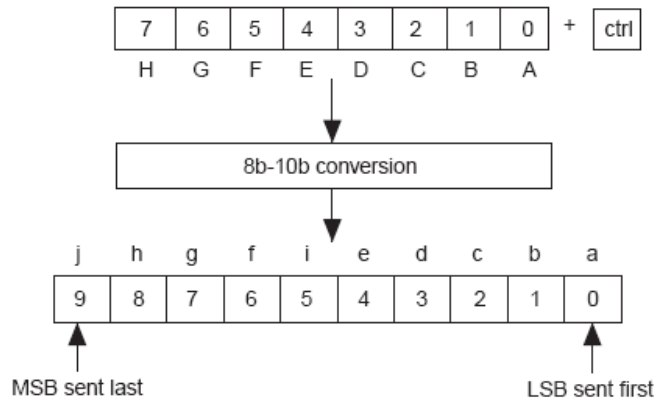

Figure 5 The 8b/10b coding diagram

### Serializer (Parallel-to-Serial Converter)

The serializer converts the parallel 8-bit or 10-bit data into a serial stream, transmitting the LSB first. The serialized stream is then fed to the transmit buffer. Figure is a diagram of the serializer.

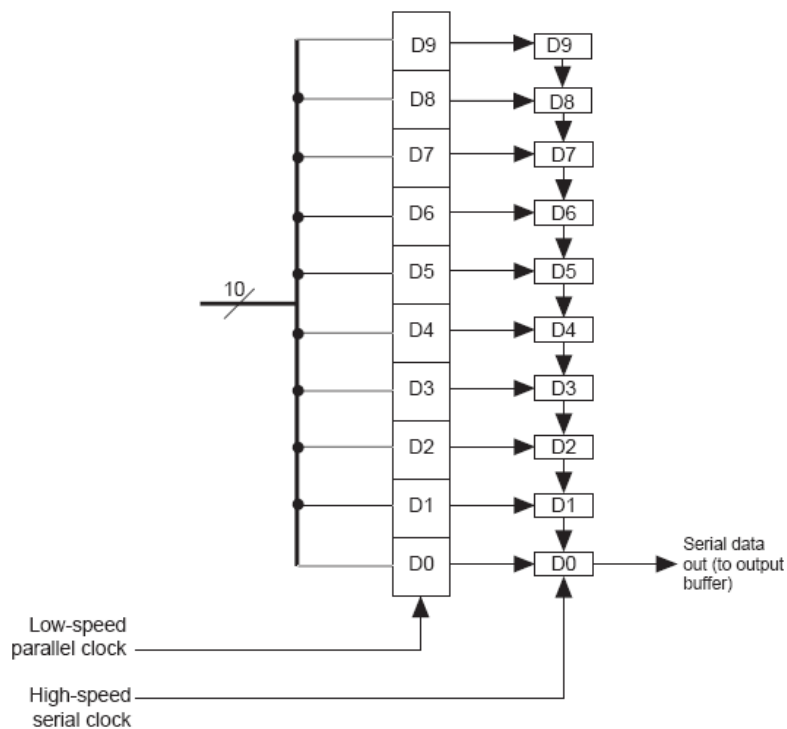

Figure 6 Parallel-to-Serial Converter Shift Register diagram

## Transmit Buffer

The Stratix GX transceiver buffers support the 1.5-V pseudo current mode logic (PCML) I/O standard at a rate up to 3.1875 Gbps, across up to 40 inches of FR4 trace, and across 2 connectors. Additional I/O standards, LVDS, 3.3-V PCML, LVPECL, can be supported when AC coupled. The common mode of the output driver is 750 mV. The output buffer, consists of a programmable output driver and a programmable pre-emphasis circuit.

## Programmable Output Driver

The programmable output driver can be set to drive out 400 to 1,600 mV. Table shows the available settings for each termination value. The VOD can be dynamically or statically set. The output driver requires either internal or external termination at the source.

Termination Setting	VOD Setting (mV)
100	400, 800, 1000, 1200, 1400, 1600
120	480, 960, 1200, 1440
150	600, 1200, 1500

Table 2 Voltage Output Driver settings in the Stratix GX devices

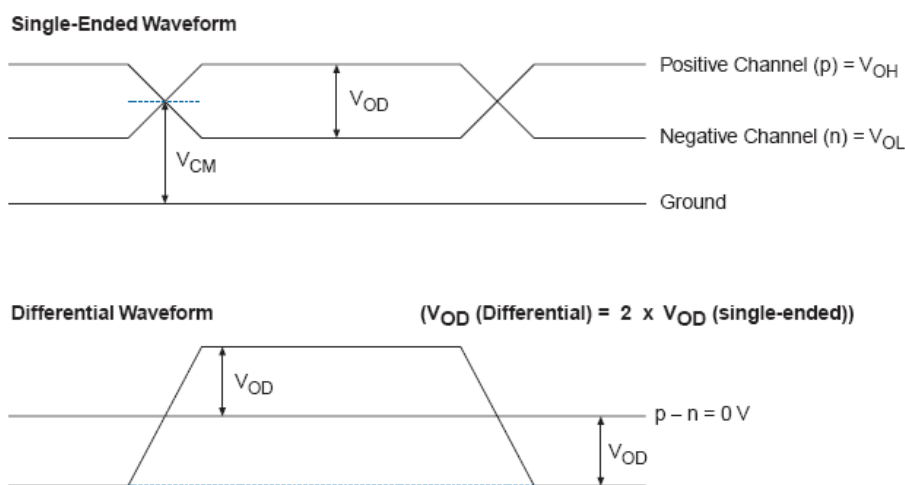

Figure 7 Single-Ended and Differential Waveforms of Programmable Output Driver

### **Programmable Transmitter Termination**

The programmable termination can be statically set in the Quartus II software. The values are 100 $\Omega$ , 120 $\Omega$ , 150 $\Omega$ , and off.

### **Receiver Path**

This section describes the data path through the Stratix GX receiver.

Data travels through the Stratix GX receiver via the following modules:

- Receiver Input Buffer
- Clock Recovery Unit (CRU)
- Deserializer
- Pattern detector and word aligner
- Rate matcher and channel aligner
- 8B/10B decoder
- Receiver logic array interface

### **Receiver Input Buffer**

The Stratix GX receiver input buffer supports the 1.5-V PCML I/O standard at a rate up to 3.1875 Gbps.. The common mode of the input buffer is 1.1 V. The receiver can support Stratix GX-to-Stratix GX DC coupling.

## Receiver PLL & CRU

Each transceiver block has four receiver PLLs and CRUs, each of which is dedicated to a receive channel. If the receive channel associated with a particular receiver PLL or CRU is not used, then the receiver PLL or CRU is powered down for the channel.

## Deserializer (Serial-to-Parallel Converter)

The deserializer converts the serial stream into a parallel 8- or 10-bit data bus. The deserializer receives the least significant bit first. Figure 2–14 is a diagram of the deserializer.

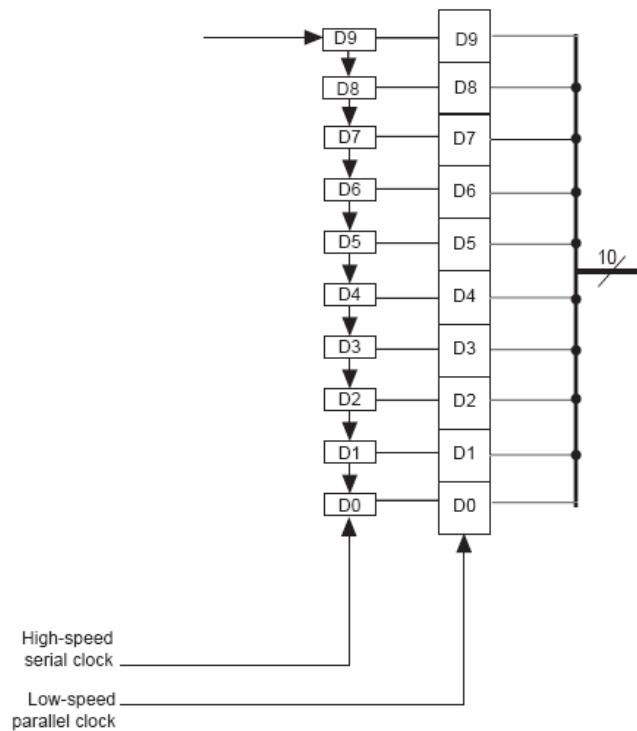

Figure 8 Serial-to-Parallel Converter Shift Register Diagram

## Word Aligner

The word aligner aligns the incoming data based on the specific byte boundaries. The word aligner has three customizable modes of operation: bit-slip mode, 16-bit mode, and 10-bit mode,

the last of which is available for the basic and SONET modes. There are several ways to align the data. Word Aligner patterns are shown on the Figure 9.

The 10-bit alignment mode with 8b/10b coding module is used in the Long-Data-Vector Transceiver Module. The auto-dynamic alignment process is achieved with the Long-Data-Vector serialization module, that controls the internal I/O pins of the hardware module of the Stratix GX transceiver.

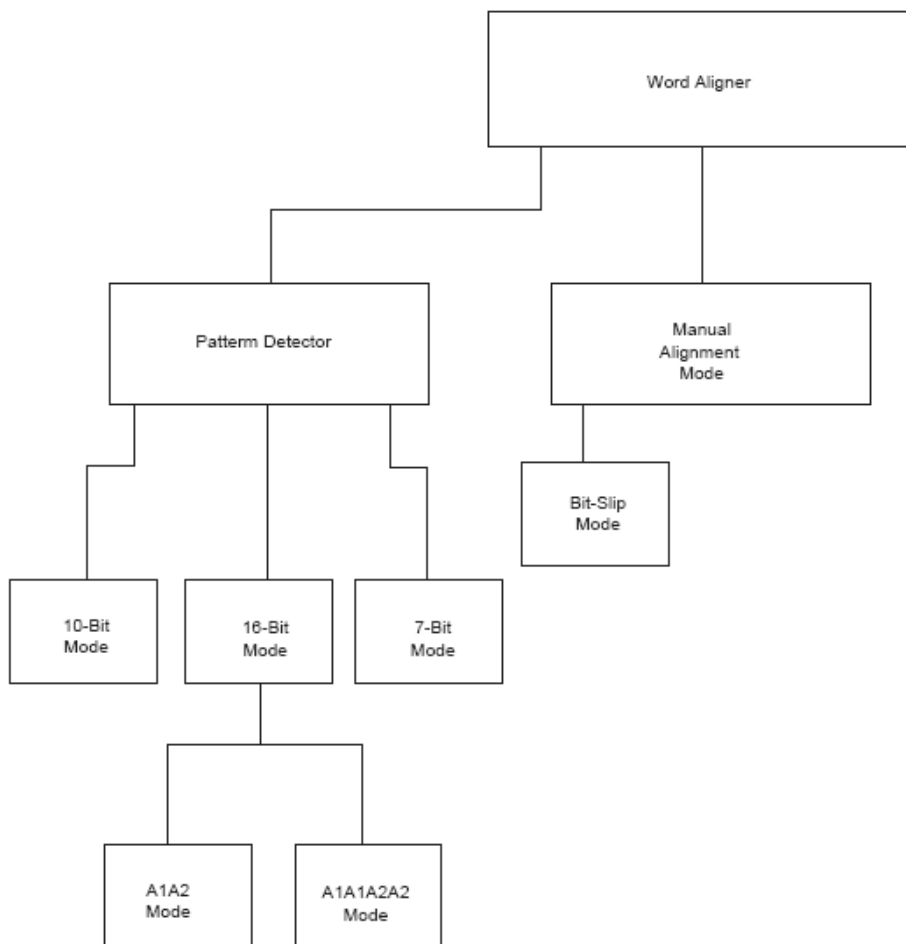

Figure 9 Word Aligner modes in Stratix GX device

The word aligner module contains a fully programmable pattern detector to identify specific patterns within the incoming data stream. The pattern detector includes recognition support

/K28.5/ comma characters for 8B/10B encoded data and A1 or A2 frame alignment patterns for scrambled signals. Additionally, you can specify a custom alignment pattern in lieu of the /K28.5/ comma. The word aligner in the gigabit transceiver block also creates words from the incoming serial data stream by realigning the data based on identified byte boundaries. The realignment function uses a barrel shifter and works with the pattern detector. Additionally, the word aligner has a manual data realignment mode that lets you control the data realignment in user mode without consistent alignment characters.

### 8B/10B Decoder

The 8B/10B decoder converts the 10-bit encoded code group into 8-bit data and 1 control bit. The 8B/10B decoder can be bypassed. The following is a diagram of the conversion from a 10-bit encoded code group into 8-bit data and 1-bit control.

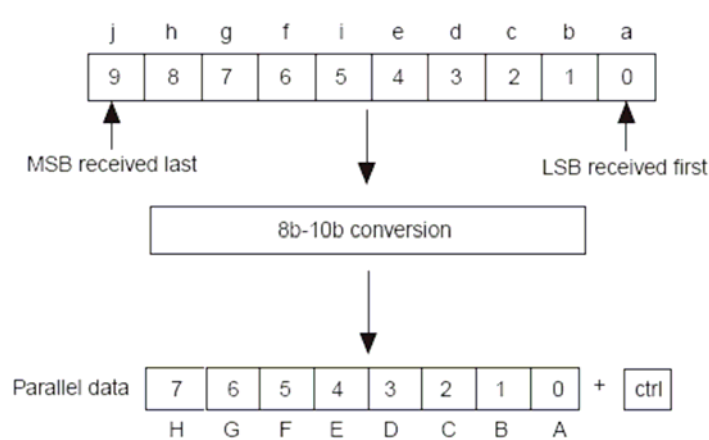

Figure 10 The 8b/10b decoding process diagram

The 8B/10B encoding/decoding is the backbone of many transceiver protocols, and it is often used in proprietary implementations. The gigabit transceiver block has dedicated circuitry to perform 8B/10B encoding in the transmitter and decoding in the receiver. This coding technique ensures sufficient data transitions and a DC balanced stream in the data signal for successful data recovery at the receiver.

## Applications & Protocols

Designers can use Stratix GX multi-gigabit transceiver blocks for a wide variety of applications. The multi-gigabit transceiver block works with a variety of industry-standard protocols, and supports proprietary custom implementations. The source-synchronous high-speed interface in Stratix GX devices is a dedicated circuit embedded into the programmable logic device (PLD) allowing for high-speed communications.

Bus Transfer Protocol	Stratix GX (Gbps) (Supports up to 3.1875 Gbps)
SONET backplane	2.488
10 Gigabit Ethernet XAUI	3.125
10 Gigabit fibre channel	3.1875
InfiniBand	2.5
Fibre channel (1G, 2G)	1.0625; 2.125
Serial RapidIO	1.25; 2.5; 3.125
PCI Express	2.5
SMPTE 292M	1.485

Table 3 Available transmission protocols in the Stratix GX device

## The Long-data-vectors Transceiver Module in the Stratix GX device

### Introduction

The long data vectors transceiver module is a source-synchronous high-speed interface, working at 2.5 Gbps. It is implemented in Stratix GX, one of the Altera FPGA family devices. The long data vectors transceiver component is described in the VHDL language, and uses internal hardware modules of Stratix® GX device in the process of data transmission. Hardware devices, dedicated to telecommunication purposes, can transmit data up to 3.125 Gbps with no resynchronization delays.

The main goals of 2.5Gbit/s transceiver module are:

- source synchronous work
- one synchronization
- bit error rate less than 10<sup>-12</sup>
- minimum I/O's
- full component control with I/O's

The FPGA based transceiver module is dedicated to transmission and reception of long bit vectors through a fiber at 2.5 Gbps. The transceiver consists of two parts: a long-vector-transmitter and a long-vector-receiver, combined in one module, but used separately. The long vector transceiver path is shown in Figure 11.



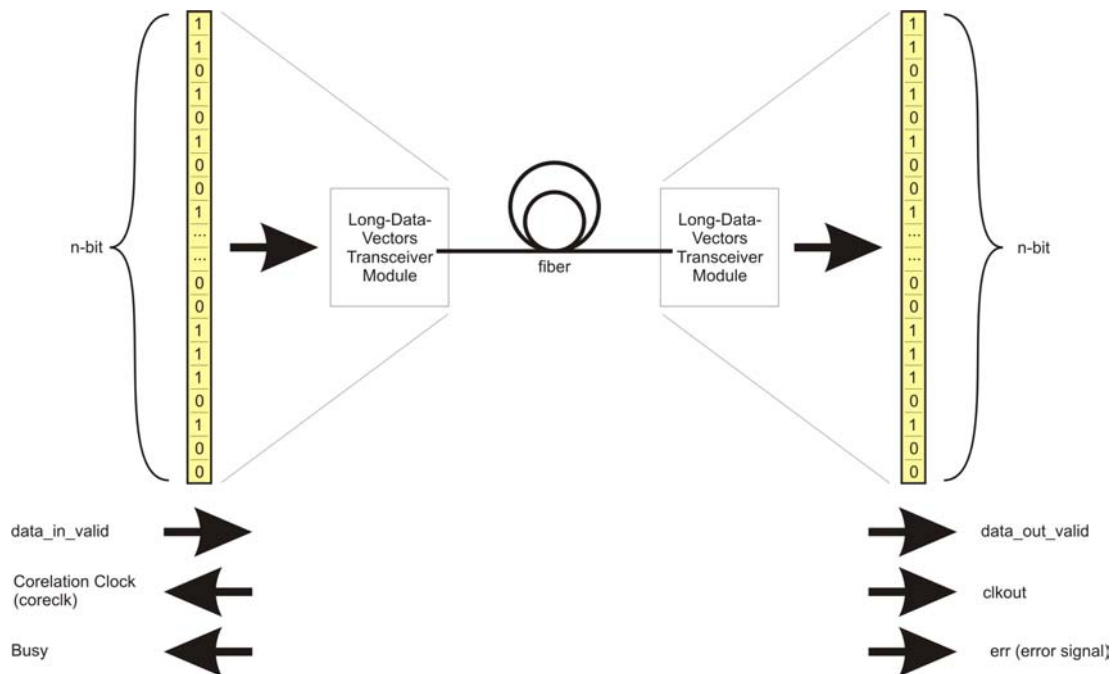

Figure 11 Schematic of the Long-Data-Vectors Transceiver Module in the Altera Stratix GX device

A long bit data vector is put by a user in the *data\_in* input of the component and confirmed with the *data\_in\_valid* signal. The serialization of data is done in two modules: the 8-bit-serialization-module and the hardware transmitter (Figure 12) which is a part of the Stratix® GX device. The FPGA chip is connected to the fiber transmitter module, where electric LVDS impulses are converted into the electric current that drives the laser led. Data travels through the fiber with the full speed of 2.5 Gbps and later received by the PIN diode fiber-receiver, which is connected to FPGA device via symmetric line in LVDS logic. The multi-gigabit voltage pulses drive the hardware components of the Stratix GX receiver module. Data recovered from the voltage stream is deserialized in the receiver module of the Stratix GX chip and the 8-bit-deserialization-module. The long-data-vector transmission path is shown in Figure 12.

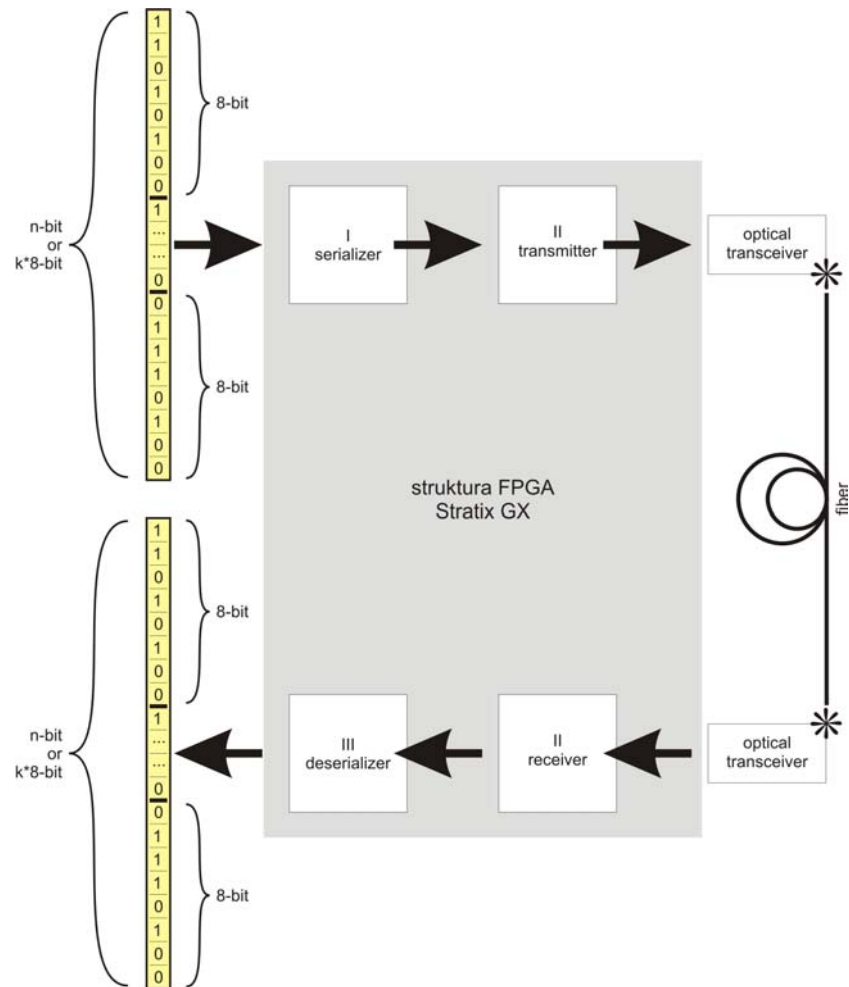

Figure 12 The long-data-vector transmission path in the designed hardware

### The Long-Data-Vector serializer

The long-data-vector serializer is the first part of the transmitter module implemented in the FPGA Stratix GX structure. The synchronic 8-bit serializer module accepts a user data vector when user *data\_in\_data\_valid* signal is high, and *coreclk*<sup>7</sup> reference clock signal goes high. The long data vector is serialized by 8 bits, and synchronously transferred to the hardware transmitter input (Figure 13)

<sup>7</sup> Correlation Clock signal in Stratix GX hardware transceiver module

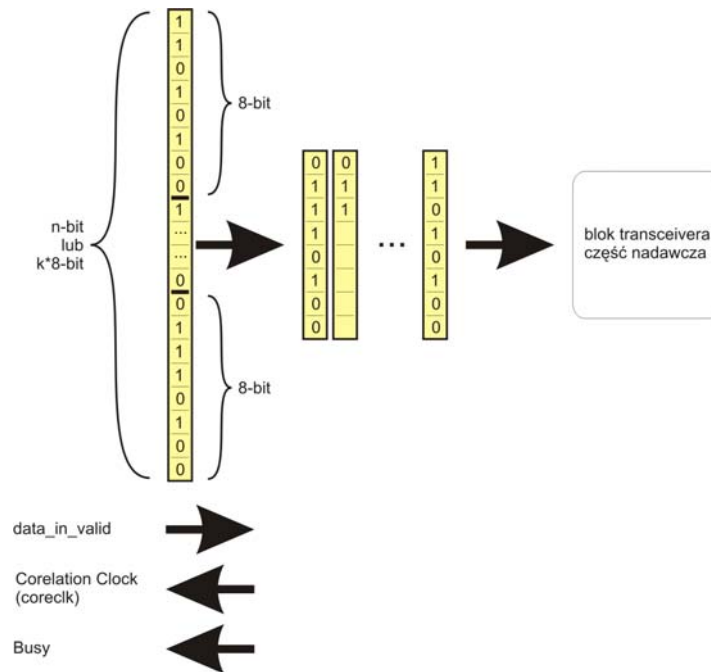

Figure 13 Long-Data-Serializer interfafe in Stratix GX device

The *data\_in\_valid* user signal is the logical validator of the input data long vector. Input vectors are always accepted when the last byte of the pervious vector is sent, in this particular moment the busy indicator goes down. If a user sends the *data\_in\_valid* signal while component is busy, all the data will be ignored and not send by the link. The *data\_in\_valid* signal given by the user goes directly to the control register. that drives all the events during the synchronous process of data serialization in the module. (Figure 14) The length of the control register depends on the *data\_in* vector length and is generated automatically during the component compilation process. The length of the control register is a number of 8-bit bytes in the *data\_in* vector. The binary representation of the control vector controls the the state of the I/O bits of the component.

The other part of the 8-bit-serialization module is the data flow path, that depends on the control buffer state. In order to minimize the latency and errors in high speed data rewriting process, it is made as a separate functional block.

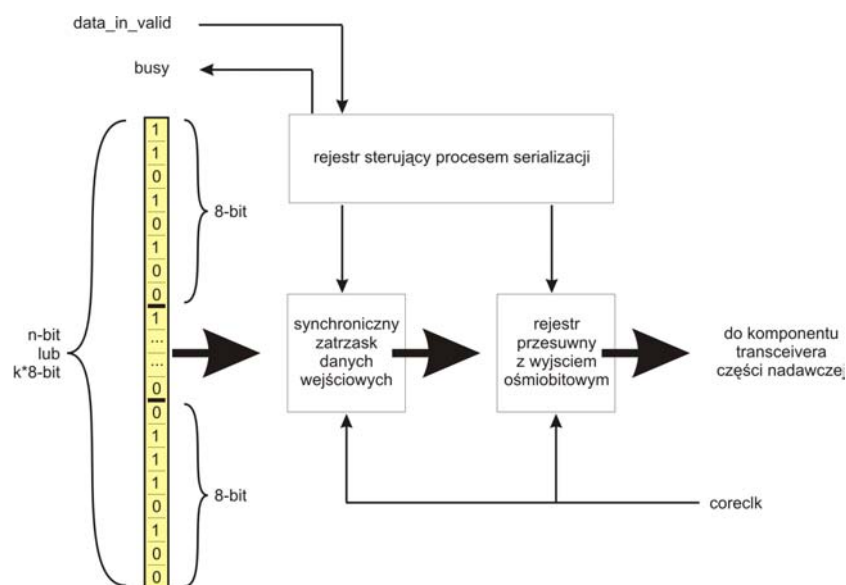

Figure 14 Control signals in the Long-Data-Vector Serializer Module in the Stratix GX device

The whole transmitter component is based on the shift registers, as only the shift registers offers a high speed data buffer-to-buffer transfer in time of less then 2ns. The high speed 8-bit-serializer is in fact 8-bit-bus-shift-register, that shifts bytes of the input data every *coreclk* rising edge.

```
reg_signal    <= reg_signal((data_length_mod8-9) downto 0) & "00000000";
data_out      <= reg_signal((data_length_mod8-1) downto (data_length_mod8-8));;
```

The input data travels from the parallel input pins directly into the shift register with the 8-bit bus. Every clock event the register shifts next 8-bits from the data vector and moves them into the hardware transmitter input. The process is done synchronously with the correlation clock rising edges. The correlation clock is generated by the PLL in the hardware tranceiver of the Stratix GX module, with the frequency of 250MHz. The lack of any between registers, or data storage lathes makes the component free of errors and unnecessary delays.

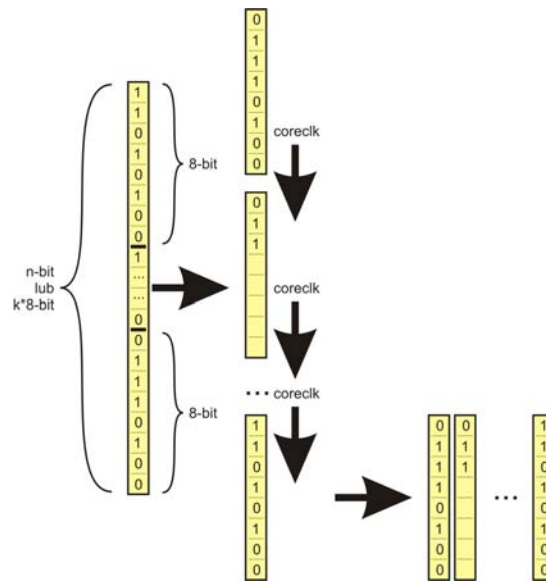

Figure 15 The data serialization process in the Long-Data-Vector serialization module

The shift register 8-bit-serializer-block construction is free of errors and unnecessary delays. The component inside buffers are such that they enable an easy reconfiguration of the Long-Data-Vector serialization module to allow it to accept data length starting from 8 bits.

```

entity mux_2500 is
generic
(
    data_length      :      integer
);
port
(
    reset           :      in      std_logic;
    clk             :      in      std_logic;
    data_in_valid   :      in      std_logic;
    data_in         :      in      std_logic_vector ((data_length-1) downto 0);
    data_out        :      out     std_logic_vector (7 downto 0);
    data_out_valid  :      out     std_logic;
    busy           :      out     std_logic
);
end entity;
```

The Long-Data-Vector serialization module is realized in the VHDL language, and it can be implemented in the Stratix GX devices. The high stability and the data reliability makes the vector serializer ideal for the multigigabit data transmissin link purposes, Component also controls the hardware transceiver module I/O pins.

### The hardware transceiver module in the Stratix GX FPGA structure

The fast, source-synchronous data transmission at 2.5 Gbps is possible because of the hardware elements in the FPGA structure. The hardware elements combined together make the transceiver module that contains of two major parts: the transmitter and the receiver. The transmitter part is dedicated to the data coding and serialization process. In the process there is used 8b/10b coding method that improves the stability, and reliability if the data flow. The coding, designed by the IBM corporation that is used in serial data transfer protocols, converts 8-bit data vectors in to 10-bit vectors, with the same number of '0' and '1' in the stream. In this process the summary energy of 0's and 1's transmitted through the link is close to zero. Data conversion process is usually used in the symmetric line transmission, and fiber connections. Both of these connections are used in the project, parallel line to connect FPGA with the fiber transceiver and the optical connection between the fiber transmitter and receiver. The Stratix GX contains of hardware transceiver module which is directly connected to the fiber transceiver module. The hardware transceiver module in FPGA structure is made of hardware blocks connected to user I/O's. (Figure 16) With the hardware transceiver I/O pins the full component control is possible.

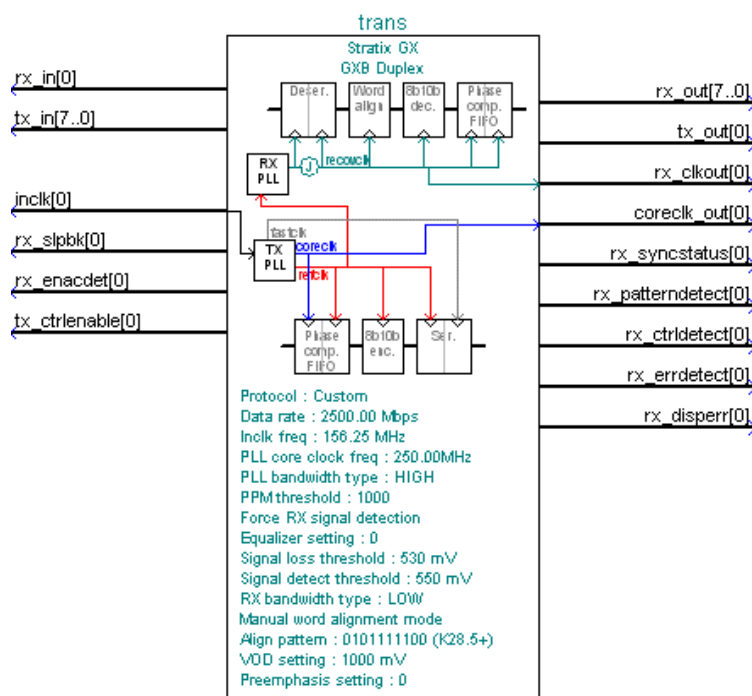

Figure 16 Hardware transceiver module in the Stratix GX device

<b>signal</b>	<b>length</b>	<b>description</b>
inclk[]	1	Transceiver block transmitter PLL reference input clock
rx_enacdet[]	1	Enables alignment to the programmed pattern.
rx_in[]	1	Transceiver block receiver channel data input port.
rx_slpbk[]	1	Reverse serial loopback input. Dynamically enables reverse serial loopback from the rx_in[] port to the tx_out[] port
tx_in[]	8	Transceiver block transmitter channel data input port.
tx_ctrlnable[]	1	Control character enable. Enables the 8B/10B encoder to identify control characters. Labels an input character as a control code
rx_disperr[]	1	Indicates whether the 8B/10B decoder detects a disparity error.
rx_patterndetect[]	1	Indicates whether the pattern detector detected the programmed pattern.
rx_ctrldetect[]	1	Indicates whether the 8B/10B decoder detects a control code.
tx_out[]	1	Serialized transceiver block transmitter channel data signal.
rx_errdetect[]	1	Indicates whether the 8B/10B decoder detects an error code.
rx_out[]	8	Transceiver block receiver PLL output data.
coreclk_out[]	1	Output clock fed by the clk2 port of the transceiver block transmitter PLL.
rx_clkout[]	1	Output clock from the transceiver block receiver channel.
rx_syncstatus[]	1	Provides the status of the pattern detector and word aligner.

### The long data vector deserializer

The long data vector deserializer module is the last part of the Long-Vector-Transceiver Component implemented in the FPGA Stratix GX structure. The fast, synchronous module accepts 8-bit data from the receiver part of the hardware Stratix GX transceiver module, and transforms them into the long data vector, corresponding with the input data vector. (Figure 17)

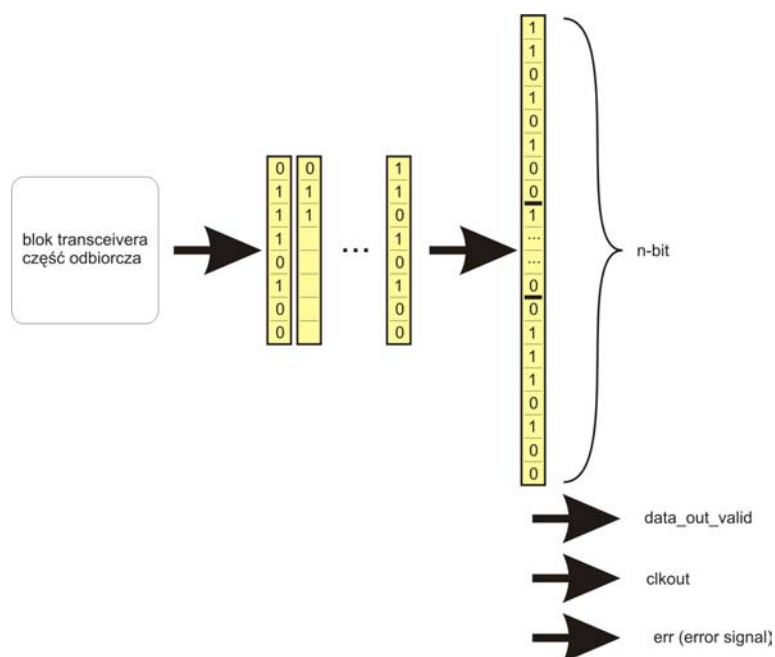

Figure 17 Data flow in the Long-Data-Vector Deserializer module in the Strztix GX structure

The vector-deserializer module accepts the 8-bit data vectors from the receiver part of the hardware Stratix GX module. The incoming data is validated by the *rx\_control\_detect* signal, that is the internal signal of the hardware transceiver module. The signal indicates if the incoming data is control or data vector. If the control string is detected then component switches into synchronization mode. If the data vectors are detected then the desalinization process occurs.



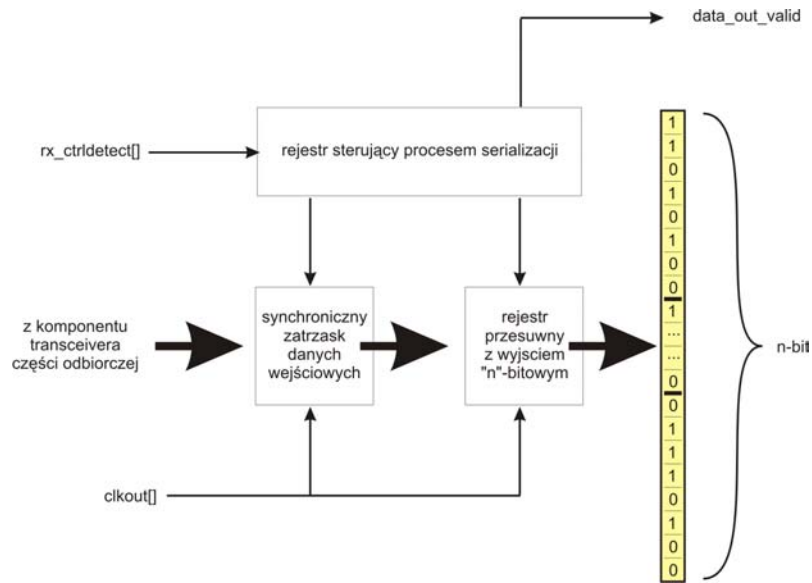

Figure 18 Control signals in the Long-Data-Vector deserialization module in the Stratix GX device

The deserialization process is dependent of the state of the control register. (Figure 18) The control register sets all the I/O's of the deserialization module. The register also controls the synchronization signals of the hardware transceiver module.

The second part of the deserialization module is a data flow part. The incoming data is latched in the internal shift buffer, that is responsible of the byte deserialization. Only the shift buffer construction make it possible to transmit the data through the registers at speed of 250MHz. Every clock event the 8-bit data in the register is shifted and transferred on the output pins of the component. If the data vector is the same as the input vector, the *data\_out\_valid* signal rises for the time of the one clock period. In order to receive the data vector for the output pins of the component a user must to latch the output data in the outside buffer.

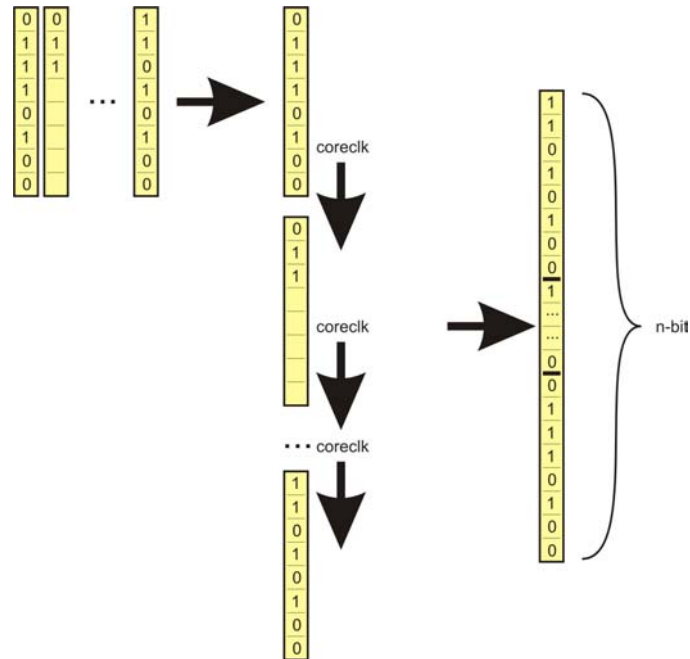

Figure 19 The deserialization process in the Data-Vector Deserialization module

The shift register in the deserialization module works in the synchronous mode. The synchronization signal is given by the hardware transceiver module. Hardware transceiver module depends of the Deserialization Module signals. The length of the control signals depend of the number of 8 bit words in the stream. 8 bit words in the data stream in right order make the output long data vector. The vector is given to a user with the *data\_out\_valid* signal, that corresponding with the valid data in the output.

### Tests of the Long-Data-Vector Transceiver Module

This section tells about the tests of the Long-Data-Vector Transceiver Module. The tests were done in the PERG laboratory, and were using all the available hardware equipment, that was necessary to fully test the component.

### Simulations in the Quartus II software

The 32-Long-Data-Vector Transceiver Module was implemented to the Quartus II 5.0 software environment.

The 32-Long-Data Vector was incremented by 2 every corelation clock rising edge. All the transmission signals were outputted into the chart, and tested together, during the simulation at full transmission speed. This test shows the synchronization process and begin of normal transmission, referring to Figure 20.

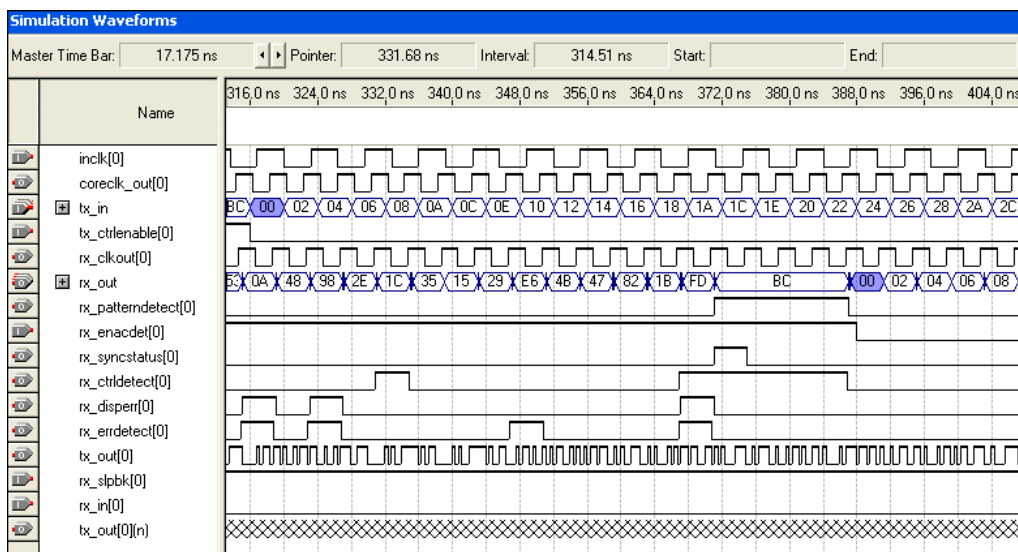

Figure 20 Data transmission simulation in Quartus II software environment

The figure shows the process of synchronization, sending the BC data, and the following bytes of the transmission data stream.

## Hardware random tests

This section tells about hardware tests using the pseudo-random techniques. Long term hardware tests were necessary to test the work of the component.

Hardware test was using the Internal Interface and PC Matlab environment. The graphical user interface was created to make the test users friendly (Figure 21).

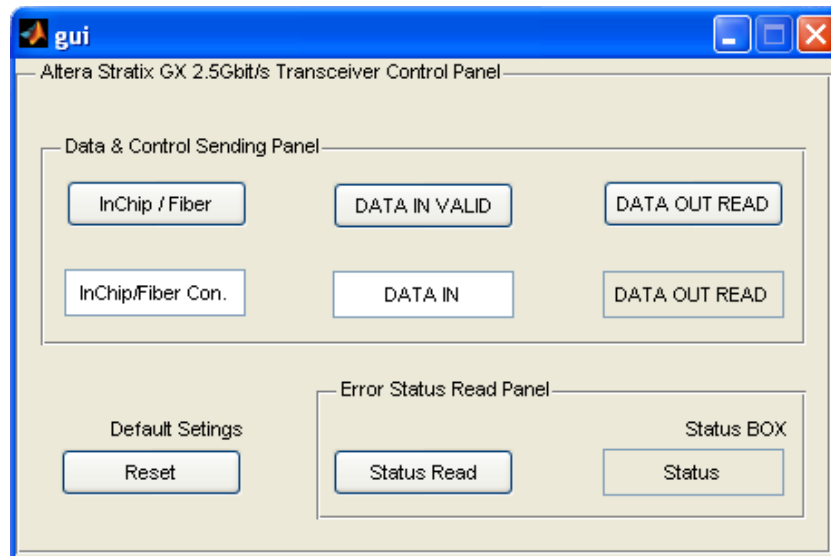

Figure 21 GUI for the hardware random test using the Long-Data-Vector Transceiver Module

First step of the Hardware Random Test was to send and receive the same data. The static data was set at the input of the component and send continually by the link at full speed. The output data was received in the output and transmitted by the Internal Interface to the PC. The data was displayed in the Matlab GUI. No errors were found during the test.

Sending the static data stream was only the first step of the test. The second step was to increment the input data stream by the static number of bits. The incremented every rising edge of correlation clock data vector was putted in to input and into the FIFO. The output data, that was

received from the output, was compared with the proper data word in the FIFO, bit by bit. During the 104 hours of test no errors was found in the transmission process.

The random hardware test was the last of the ending tests performed on the component. The input and the output was connected to the random generator. The output and input word was changing in the same way. The next word was created in a base of the last, so that in the proper transmission process the difference between the output word and the next output word stays the same. This test lat for 208 hours at full speed 2.5 Gbps, without any between resynchronization.

### Summary

The Long-Data-Vector Transceiver Module is dedicated for the data transmission in TESLA control system. The Component works in the Stratix GX environment, transmitting data at 2.5 Gbps in source synchronous mode. The Long-Data-Vector Transceiver Module has the parametric input, *data\_in* signal, that corresponding with the length of the output data vector, *data\_out* signal. User can use the correlation clock, *coreclk* signal, to synchronize the input data by driving the *data\_in\_valid* signal in the exact points of time. The output data is synchronized with the output correlation clock *clkout*, and the *data\_out\_valid* signal. The *data\_out\_valid* signal in high state indicates that data is ready to receive by a user. The signal last for the one clock cycle. Component latency with 16bit word length setting is minimal and equal to 120ns.

```
component transceiver_2500 is
generic (
  data_length      :      integer);
port(
  clk              :      in      std_logic;
  reset           :      in      std_logic;
  data_in         :      in      std_logic_vector (data_length-1 downto 0);
  data_in_valid   :      in      std_logic;
  rx_in          :      in      std_logic;
  slpbk          :      in      std_logic;
  busy           :      out     std_logic;
  data_out       :      out     std_logic_vector (data_length-1 downto 0);
  data_out_valid :      out     std_logic;
  coreclk        :      out     std_logic;
  clkout         :      out     std_logic;
  tx_out         :      out     std_logic;
  err            :      out     std_logic);
end component;
```

The Lang-Data-Vector Transceiver described in the VHDL Language

Component inputs are as follows:

- *clk* – general clock input, 156,25MHz
- *reset* – component general reset
- *data\_in* – data input form external source
- *data\_in\_valid* – input data validation signal

- rx\_in – serial signal input in LVDS format
- slpbk – serial loopback

Component outputs are as follows:

- data\_out – data output
- data\_out\_valid – output data validation signal
- coreclk – input side corelation clock signal
- clkout – output side cerelation clock signal
- tx\_out – serial signal output in LVDS format
- err – error signal

The control section and the data flow section of the component is made of shift registers. The shift registers need minimum number of gates to work properly. Minimum usage of registers, and non-complex build of the component makes it to work at 2.5Gbps, with BER less than 10<sup>-15</sup>.

The algorithm was prepared so it can correspond with hardware 8-bit transceiver module, that can transfer data at 1.250, 1.500, 2.100, 2.500 and 3.125 Gbps.

The component has multi-bit input, that can be configured in the definition generics section of the component itself. If the length of the input word is not multiplication of the 8 bit vector, the algorithm sets the correct number of bits automatically, n bits are added to the string.

Multi-bit word structure can be used to make the component compatible to the other devices. Basic tests shown that the component is compatible with the Xilinx Virtex II PRO device, 16 bit data strings were sent and received during the transmission.

The component is synchronized and resynchronized automatically, when valid data is not sent. It takes about 100ns after power up to synchronize the link. The transmission can be provided nonstop after synchronization process.

Tests of the Long-Data-Vector Transceiver Module

---

<b>parameter</b>	<b>signal</b>	<b>I/O</b>	<b>value</b>
word length	data_length	generic	integer greater then 8
oscilator	clk (in)	in	156,25MHz
reset signal	reset	in	bit
input data	data_in	in	bit_vector (variable)
input data valid signal	data_in_valid	in	bit
data stream input	rx_in	in	bit (LVDS 1,5V)
loopback	slpbk	in	bit
device busy signal	busy	out	bit
output data	data_out	out	bit_vector (variable)
output data valid signal	data_out_valid	out	bit
input correlation clock	coreclk	out	250MHz (4ns)
output correlation clock	clkout	out	250MHz (4ns)
data stream output	tx_out	out	bit (LVDS 1,5V)
error indicator	err	out	bit

<b>parameter</b>	<b>value</b>
oscilator	156,25MHz
data transfer	2,5Gbit/s
input data length	variable
input of data	synchronic
correlation clock	250MHz
link synchronization	automatic



**Literature**

- [1] T. Czarski, R. S. Romaniuk, K.T. Poźniak “Cavity Control System, Models Simulations For TESLA Linear Accelerator ”, TESLA Technical Note, 2003-09:
- [2] T. Czarski, K. Poźniak, R. Romaniuk, S. Simrock: TESLA Cavity Modeling and Digital Implementation with FPGA Technology Solution for Control System Purpose. TESLA internal note 2003-28.
- [3] K. T. Poźniak, M. Bartoszek, M. Pietrusinski, Internal interface for RPC muon trigger electronics at CMS experiment, Proceedings of SPIE, Bellingham, WA, USA, Vol. 5484, 2004, pp. 269-282.
- [4] Waldemar Koprek, Paweł Kaleta, Jarosław Szewiński, Krzysztof T. Poźniak, Ryszard S. Romaniuk: Software Layer for SIMCON ver. 1.1., FPGA based TESLA Cavity Control System; USER’S MANUAL. TESLA internal note 2005-05.
- [5] W. M. Zabolotny, P. Roszkowski, K. Poźniak, R. S. Romaniuk, K. Kierzkowski, S. Simrock: “Distributed Embedded PC Based Control and Data Acquisition System for TESLA Cavity Controller and Simulator”, TESLA Technical Note, 2003-34
- [6] K. T. Poźniak, R. S. Romaniuk, T. Czarski, W. Giergusiewicz, W. Jałmużna, K. Ołowski, K. Perkuszewski, J.Zieliński, S.Simrock “FPGA and Optical Network Based LLRF Distributed Control System for TESLA-XFEL Linear Accelerator, TESLA Technical Note, 2004-9
- [7] W. Koprek, P.Kaleta, J.Szewinski, K.T.Pozniak, T.Czarski, R.S.Ronmaniuk: “Software Layer for FPGA-Based TESLA Cavity Control System (Part I), TESLA Technical Note, 2004-10
- [8] Krzysztof T. Pozniak, Ryszard S. Romaniuk, K. Kierzkowski: “Modular & reconfigurable common PCB-platform of FPGA based LLRF control system for TESLA Test Facility” TESLA Technical Note, 2004-x
- [9] Using Quartus II Verilog HDL & VHDL Integrated Synthesis; Application Note 238; December 2002, Altera Corporation

- [10] Optimizing FPGA Performance Using the Quartus II Software; Application Note 297; May 2003, Altera Corporation
- [11] Stratix Device Handbook, Volume 1; Stratix Device Family Data Sheet; ; April 2003; Altera Corporation
- [12] Stratix GX Device Handbook; Stratix GX FPGA Family Data Sheet; January 2005; Altera Corporation
- [13] Stratix GX Transceiver User Guide; December 2003; Altera Corporation
- [14] Implementing 10 Gigabit Ethernet XAUI in Stratix GX Devices; Application Note 249; November 2002, ver. 1.0; Altera Corporation
- [15] High-Speed Development Kit, Stratix GX Edition User Guide; Document Version: 1.0; July 2003; Altera Corporation
- [16] “Agilent HFBR-5921L/HFBR-5923L Fibre Channel 2.125/1.0625 GBd 850 nm Small Form Factor Pin Through Hole (PTH) Low Voltage (3.3 V) Optical Transceiver”, Data Sheet, Agilent Technologies, 2002
- [17] “Infineon V23818-M305-B57 Small Form Factor Pluggable SFP Multimode 850 nm 2.125 and 1.0625 GBd Fibre Channel Transceiver with LC™ Connector”, Data Sheet, Infineon Technologies, January 2002
- [18] A.X.Widmer, P.A.Franaszek: “A DC-balanced, partitioned-block, 8b/10b transmission code”, IBM Journal of Research and Development, vol 27, no 5, 1983, pp. 440-451
- [19] <http://www.altera.com/> [Altera Homepage]
- [20] <http://www.xilinx.com/> [Xilinx Homepage]
- [21] <http://www.mathworks.com> [Matlab homepage]
- [22] <http://www.RapidIO.org>